

4 Tonne - The heavy hitter

The largest machine in the EcoPlant range and the most powerful demolition robot available on the market today. Its performance outbreaks a several times heavier conventional excavator, still it's agile and small enough to work in tight spaces. With the impressive weight/power ratio this machine has the muscle to demolish any concrete structure while eliminating the need of expensive shoring. It is also very productive in open spaces. Other keywords relevant for this page: Jack hammers, rock breakers

MOTOR: 30Kw
HEIGHT: 1640mm
WIDTH: 1500mm

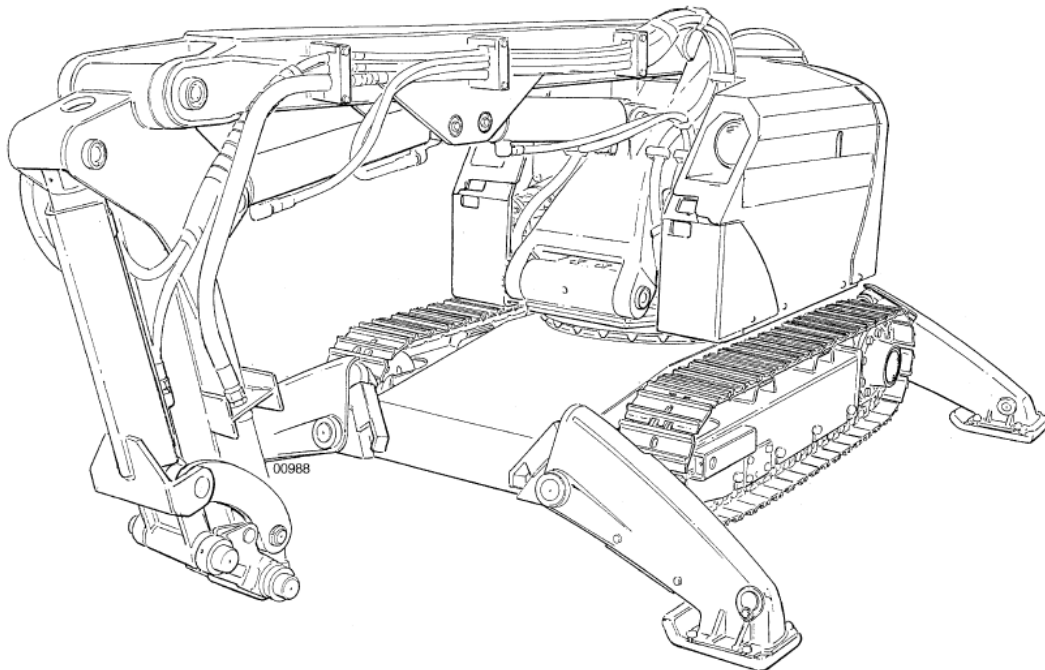

HYDRAULIC SYSTEM

Type of pump	Variable displacement loadensing
Pressure	16,5 MPa
Flow	0-100 l/min (0-26 US gal/min)
ELECTRIC MOTOR	
Output	30kW
Number or revolutions	See marking
Voltage/Frequency	See marking
Amperage	See marking
Starting device	Y/D starter
CONTROL SYSTEM	
Control unit	Remote control box
Signal code	Digital
Control mode	Cable

Technical Data

MEASUREMENTS		
Transport length excl attachment	3920 mm	154 in
Transport hight, lowest	1540 mm	60,6 in
Transport width, outriggers folded	1500 mm	58,9 in
Ground clearance, approx	200 mm	7,9 in
Operating width, outriggers folded	2430 mm	95,7 in
Track gauge	250 mm	9,8 in
WEIGHT		
Weight complete excl attachment	4100 kg	9030 lb
Load tracks, excl attachment	0,055 N/mm ²	
Weight, hammer, max	550 kg	1210 lb
PERFORMANCE		
Unlimited revolutions		
Slewing speed	14 sec/360	
Maximum travel speed	1,8 km/h	1,1 mi/h
Gradient	30°	

Dimension in m (ft)

