

1 Tonne - When size matters

When it comes to working in confined spaces, size does matter. With its compact design and heavy-duty capacity, this machine is small and agile enough to get into tight spots, yet it still packs enough of a punch for those bigger jobs. For maximum versatility in a tool for use in confined spaces, the 1 Tonne machine is the perfect choice - demolition in a class of its own!

MOTOR: 11Kw
HEIGHT: 1210mm
WIDTH: 780mm

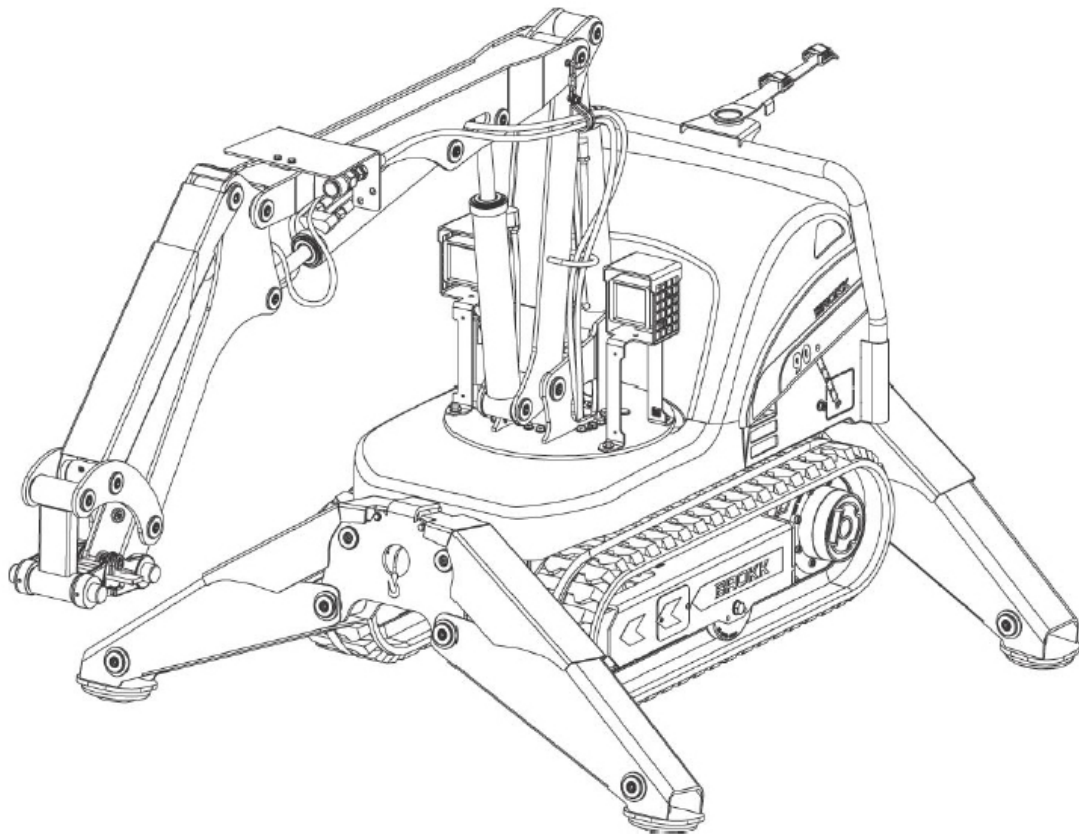

Technical Data

Hydraulic breaker in illustrations	SBC 255
Load and stability diagram can be ordered	
Performance	
Slewing speed	8 sec/245°
Transport speed, max.	2,6 km/h; 0,8 m/s; 1,6 mph
Incline angle, max.	30°
Hydraulic system	
Hydraulic system capacity	35 l; 9,2 US gal
Pump type	Gear pump with fixed displacement
System pressure	16,5 MPa; 2393 psi
Pump flow max* 50Hz and 60Hz	40 l/min; 10.6 US gal/min
Electric motor	
Type	ABB M2AA 132 MB
Output	See type plate
RPM	See type plate
Voltage/frequency	See type plate
Current	See type plate
Starting device	Smooth start
Control system	
Control type	Portable control box
Signal code	Digital
Transfer	Cable/Radio
Weight	
Weight of basic machine excluding attachment	980 kg; 2160 lb
Noise level	
Sound power level Lwa, measured according to directive 2000/14/EC	86 dB(A)

